

SPICER[®] AXLE

MAINTENANCE MANUAL

MODEL

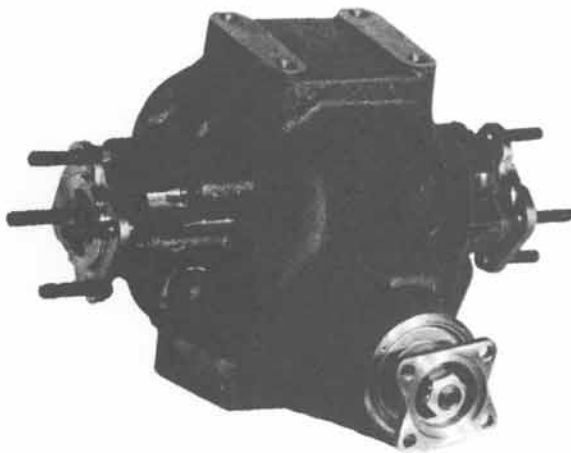

INDEPENDENT
REAR SUSPENSION

44

SPICER AXLE DIVISION



DANA CORPORATION

FORT WAYNE, INDIANA

INDEX

LUBRICATION	3
IDENTIFICATION OF SERVICE TOOLS	4
ARRANGEMENT OF COMPONENTS	5
AXLE IDENTIFICATION	6
SHAFT ASSEMBLY REPLACEMENT	6
DIFFERENTIAL CARRIER DISASSEMBLY	8
DISSASSEMBLY AND ASSEMBLY OF STANDARD DIFFERENTIAL	11
REASSEMBLY	13

IMPORTANT SAFETY NOTICE

Should an axle assembly require component parts replacement, it is recommended that "Original Equipment" replacement parts be used. They may be obtained through your local service dealer or other original equipment manufacturer parts supplier. **CAUTION: THE USE OF NON-ORIGINAL EQUIPMENT REPLACEMENT PARTS IS NOT RECOMMENDED AS THEIR USE MAY CAUSE UNIT FAILURE AND/OR AFFECT VEHICLE SAFETY.**

Proper service and repair is important to the safe, reliable operation of all motor vehicles or driving axles whether they be front or rear. The service procedures recommended and described in this service manual are effective methods of performing service operations. Some of these service operations require the use of tools specially designed for the purpose. The special tool should be used when and as recommended.

It is impossible to know, evaluate, and advise the service trade of all conceivable ways in which service might be done or of the possible hazardous consequences of each way.

Accordingly, anyone who uses a service procedure or tool which is not recommended must first satisfy himself thoroughly that neither his safety nor vehicle safety will be jeopardized by the service methods he selects.

NOTE

Throughout this manual, reference is made to certain tool numbers whenever special tools are required. These numbers are numbers of Miller Special Tools, 32615 Park Lane, Garden City, Michigan 48135. They are used herein for customer convenience only. Dana Corporation makes no warranty or representation to these tools.

LUBRICATION

It is not our intent to recommend any particular brand or make of lubricant for the Spicer hypoid axles. However, an S.A.E. 90 weight multi-purpose gear lubricant meeting Mil. Spec. L-2105-B, or 80 W 90 multi-purpose gear lubricant meeting Mil Spec. L-2105-C, and suitable for A.P.I. Service Classification GL-5 is suggested as a minimum requirement.

Motor vehicles are operated under various requirements, conditions, and environments. This manual specifies the minimum requirements that the lubricants should meet. However, it is recommended that the lubricants specified by the vehicle manufacturer be used. They may provide additional lubricating characteristics which may be required for your vehicle's operation. Contact your local service dealer or refer to your owner's manual for obtaining the proper lubricant specification.

COLD WEATHER OPERATION

If the vehicle is operated below 0°F (-18°C), it is advisable to use S.A.E. 80 multi-purpose gear lubricant meeting Mil Spec. L-2105-B, and suitable for A.P.I. Service Classification GL-5.

SUBMERSION OR DEEP WATER FORDING

In the event the gear carrier should become submerged in water, particularly if over the breathers, it is recommended that the hypoid gear lubricant be drained and internal parts be inspected for water damage and/or contamination.

Clean, examine and replace damaged parts, if necessary, prior to assembling the cover and refilling with the specified hypoid lubricant.

NOTE

It is recommended that whenever bearings are removed they are to be replaced with new ones, regardless of mileage.

NOTE

Limited Slip Differentials for Model 44-ICJ Independent Rear Axle Assemblies are serviced as complete assemblies only. Follow the differential installation procedures recommended in this manual if a new differential is required.

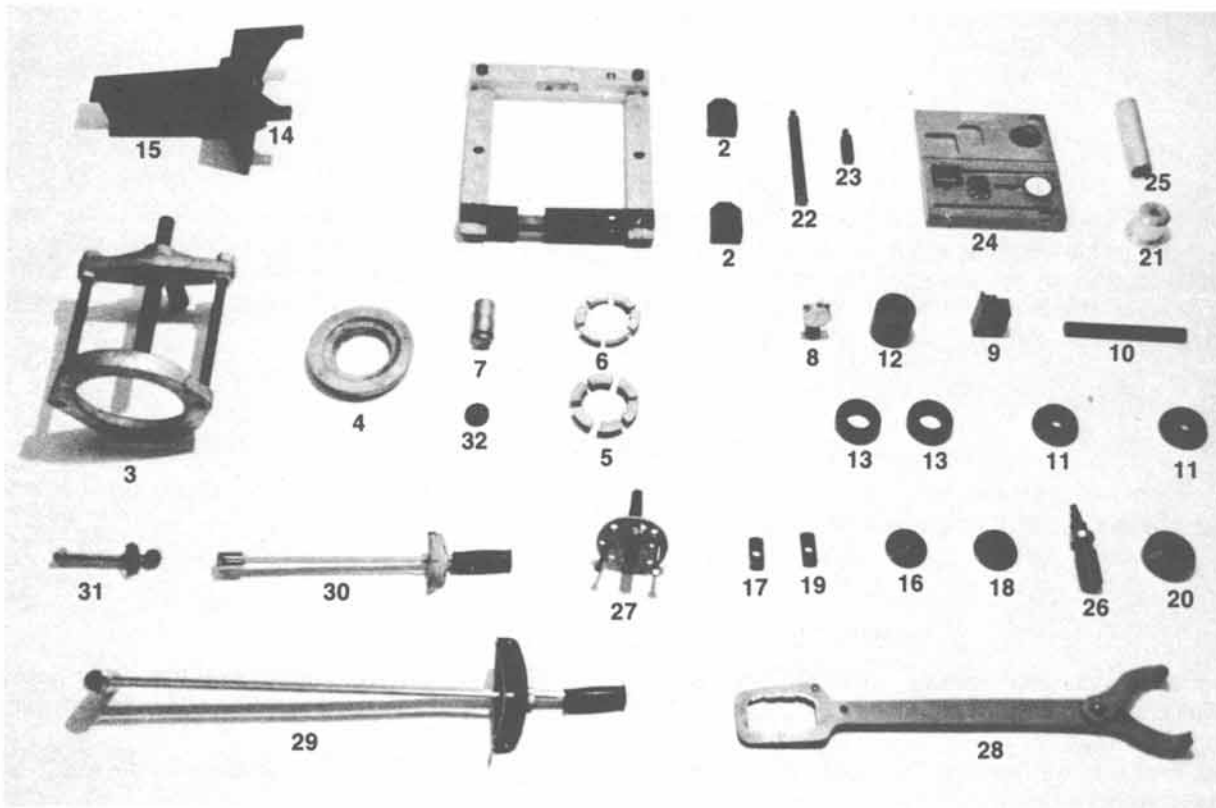

Figure 2

5329-2

The following is a detailed list of all special tools required to service the Model 44 Independent Rear Suspension Assembly.

Item No.	Tool No.	Description	Item No.	Tool No.	Description
1	D-113	Spreader	18	D-144	Installer — Outer Pinion Bearing Cup
2	D-227-1	Spreader Adapters	19	D-147	Remover — Outer Pinion Bearing Cup
3	DD-914-P	Press	20	D-156	Installer — Differential Side Bearings
4	DD-914-9	Adapter Ring	21	W-147-E	Installer — Pinion Oil Seal
5	C-293-39	Adapter Set — Rear Pinion Bearing Cone	22	C-4171	Handle — Universal
6	C-293-18	Adapter Set — Differential Bearing Cones	23	C-4291	Extension — Universal
7	C-293-3	Adapter Plug — Differential Hub	24	D-128	Dial Indicator Set
* 8	D-115	Scooter Gauge	25	W-262	Installer — Inner Pinion Bearing Cone
* 9	D-115-1	Pinion Height Block	26	W-162	Installer — Flange
*10	D-115-3	Arbor	27	C-452	Remover — Flange
*11	D-115-4-44	Arbor Discs	28	C-3281	Wrench — Flange Holder
*12	D-139	Master Pinion Block	29	C-4053	Torque Wrench (300 Ft.-Lb.)
*13	D-345	Master Differential Bearing	30	C-3952-A	Torque Wrench (150 Ft.-Lb.)
14	D-245	Supporting Fixture	31	D-193	Torque Wrench (50 In.-Lb.)
15	D-246	Vise Adapter	32	C-4487-1	Adapter
16	D-145	Installer — Inner Pinion Bearing Cup			
17	D-148	Remover — Inner Pinion Bearing Cup			

*Pinion Setting Gauge and Master Differential Kit D-115-44.

Torque Wrenches, C-4053, C-3952-A, and D-193 are optional and can be purchased separately. These Torque Wrenches are not included in the DW-44-ICJ Axle Tool Kit.

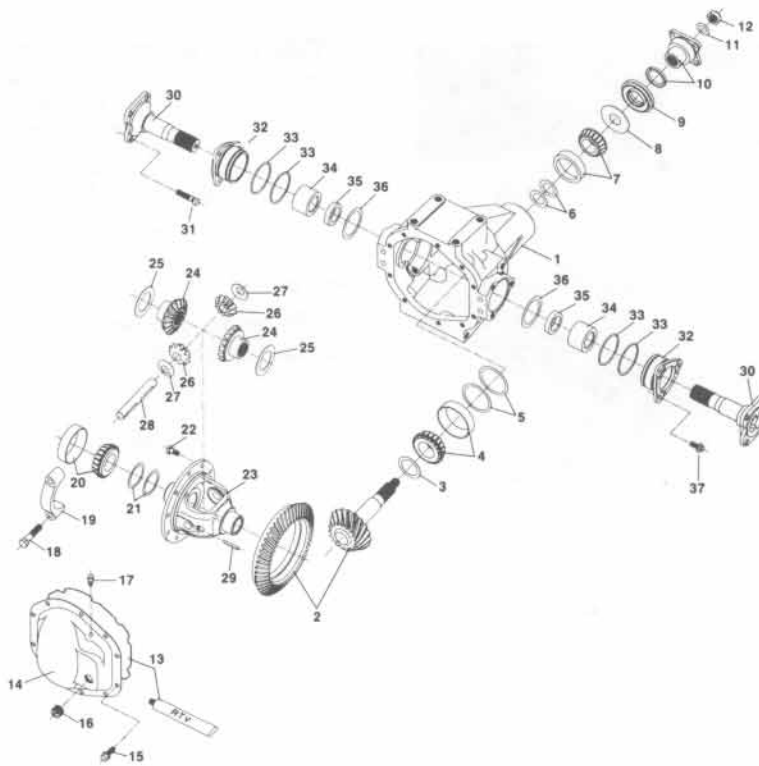

Figure 3

5329-3

IDENTIFICATION AND ARRANGEMENT OF COMPONENTS:

Item No.	Description	Item No.	Description
1	Carrier	20	Bearing — Differential
2	Drive Pinion & Gear Assembly	21	Shims — Differential Bearing Preload
3	Shim — Pinion Adjusting (Method B)	22	Screw — Ring Gear
4	Bearing — Inner Pinion Position	23	Case — Differential
5	Shims — Pinion Adjusting (Method A)	24	Gear — Differential
6	Shims — Pinion Bearing Preload	25	Thrust Washer — Differential Gear
7	Bearing — Outer Pinion Preload	26	Pinion — Differential
8	Slinger — Outer	27	Thrust Washer — Differential Pinion
9	Seal — Pinion Oil	28	Shaft — Differential
10	Flange Assembly — Companion	29	Roll Pin — Shaft
11	Washer — Pinion Nut	30	Shaft — Output
12	Nut — Pinion	31	Bolt — Output Shaft
13	Sealer — Silicone Rubber	32	Retainer — Bearing
14	Cover — Carrier	33	“O” Ring
15	Screw — Carrier Cover	34	Bearing — Output Shaft
16	Plug — Fill	35	Ring — Bearing Retainer
17	Vent — Breather	36	Shim — Bearing Retainer
18	Screw — Bearing Cap	37	Screw — Retainer
19	Cap — Bearing		

AXLE IDENTIFICATION

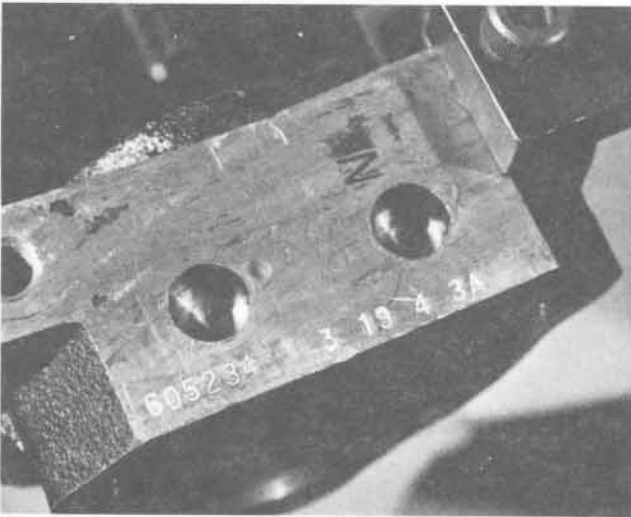

Figure 4

5329-4

All Spicer axles are identified with a manufacturing date and the complete part number. The Spicer Independent Rear Suspension assembly is identified by numbers which are stamped on the carrier.

This axle is identified with 1/8" (3.17 mm) high stamped numbers. The number 605234-1 is the Spicer part number for this particular assembly and is interpreted as follows. The number 605234 means this assembly is a Spicer Model 44 Independent Rear Suspension. The 1 (dash 1) means this unit is equipped with a 3.07:1 gear ratio and standard differential. Other dash numbers refer to other ratios and/or options.

The set of numbers adjacent to the complete part number is the manufacturing or build date. When referring to the axle assembly, obtain the complete part number and build date. To do this, it may be necessary to wipe or scrape dirt, etc., from the assembly.

NOTE

Follow vehicle manufacturer's recommendations to remove carrier from vehicle.

SHAFT ASSEMBLY REPLACEMENT

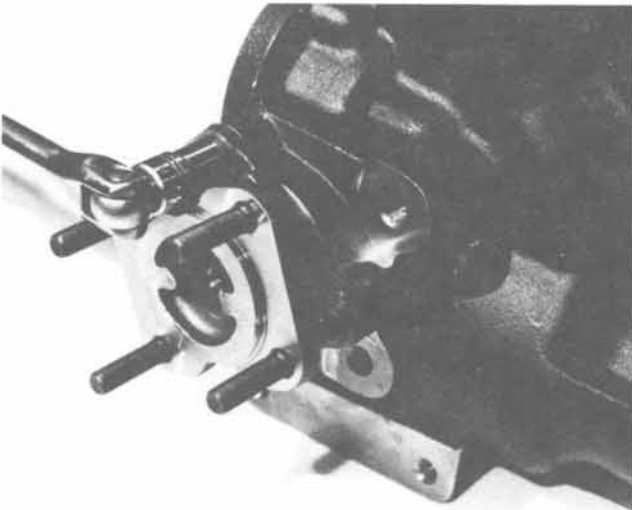

Figure 5

5329-5

Remove the retainer plate screws that retain the axle shaft assemblies in position. Remove the axle shaft assemblies. Tag the shim stack found behind the axle shaft bearing indicating which side it was from.

The axle shaft assembly is serviced as a complete assembly only. Should any component need replacement, a new axle shaft assembly is required.



Figure 6

5329-6

Remove the old axle shaft assembly "O" rings. Make sure the axle shaft assembly "O" ring grooves are clean and free of any contamination. Lubricate new "O" rings and install in the "O" ring grooves.

SHAFT ASSEMBLY REPLACEMENT

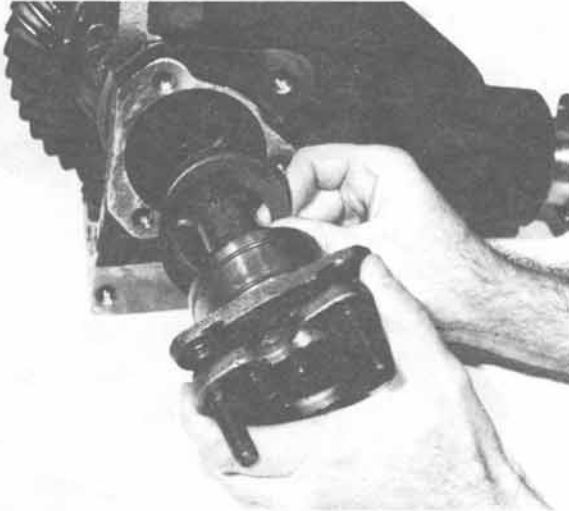

Figure 7

5329-7

Assemble the axle shaft assemblies and corresponding shim stack which was removed earlier into the carrier.



Figure 9

5329-9

Check clearance between the retainer plate and carrier as shown. There must be at least .002 in. (.05 mm) and not more than .005 in. (.13 mm) clearance so that the axle shaft bearing is properly preloaded. To correct improper clearance, add or subtract shims from the shim stack accordingly. Bent or mutilated shims should be replaced with new ones. Shims are available in .003 in. (.08 mm), .005 in. (.13 mm), .010 in. (.25 mm), and .030 in. (.76 mm) thicknesses.

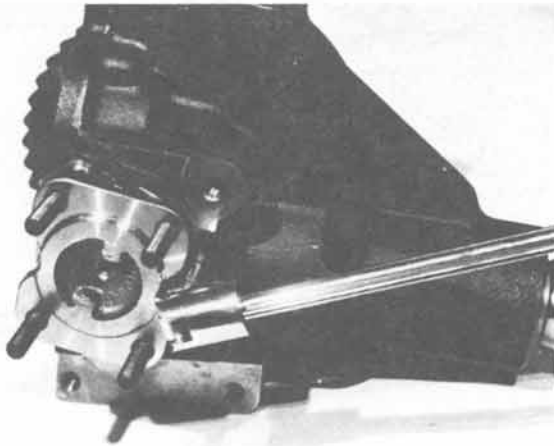

Figure 8

5329-8

Torque the retainer plate screws to 35-45 lbs-ft (47-61 N•m).

DIFFERENTIAL CARRIER DISASSEMBLY

Follow the vehicle manufacturer's recommendations for carrier removal and installation procedures from vehicle. Remove the cover and drain the lubricant. Remove the axle shaft assemblies as outlined in this manual.

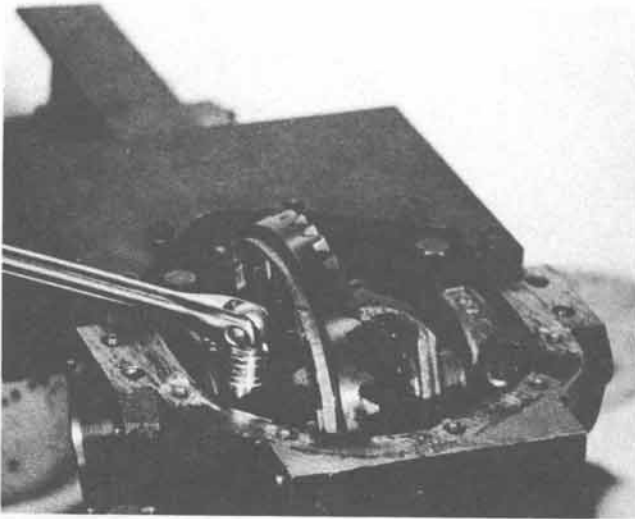

Figure 10

5329-10

Mount the carrier in a fixture as shown.

Remove the bearing caps. Note the matched letters stamped on the caps and carrier. When assembled, the letters on the caps must agree in both the horizontal and vertical position with the letters on the carrier.

Tools: D-245 Supporting Fixture
D-246 Vise Adapter

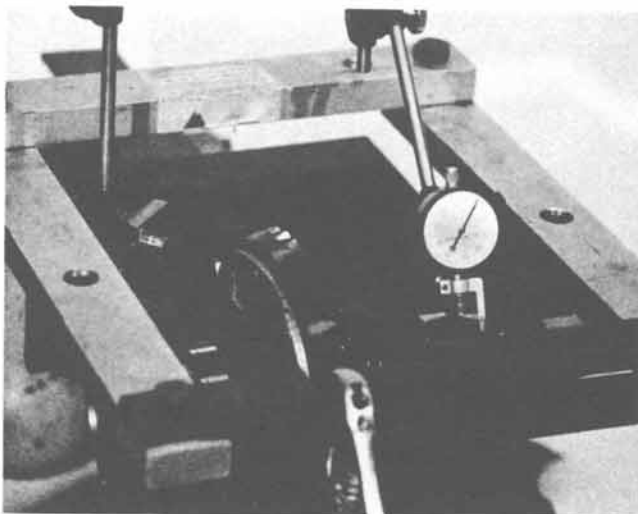

Figure 11

5329-11

Mount the spreader to the carrier. Use a dial indicator as shown. **DO NOT SPREAD CARRIER OVER .010" (.25 mm).** Remove the indicator.

Tools: D-113 Spreader
D-128 Indicator Set
D-227-1 Spreader Adapters

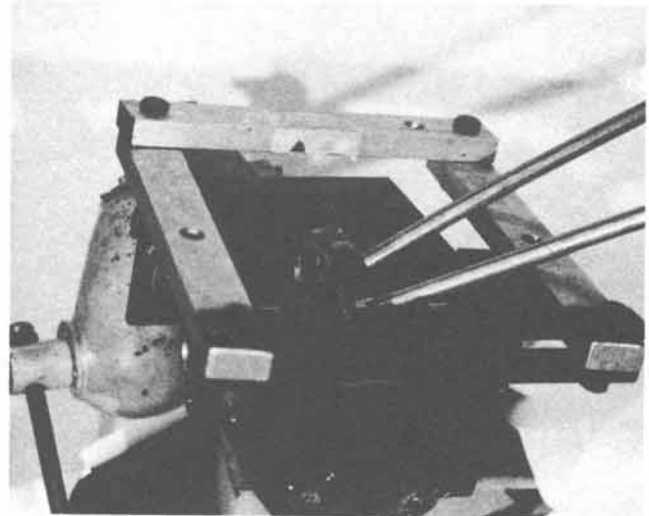

Figure 12

5329-12

Pry the differential case from the carrier with two pry bars. After the differential case and ring gear have been removed, remove the spreader. Use caution to avoid damage to any machined surface.

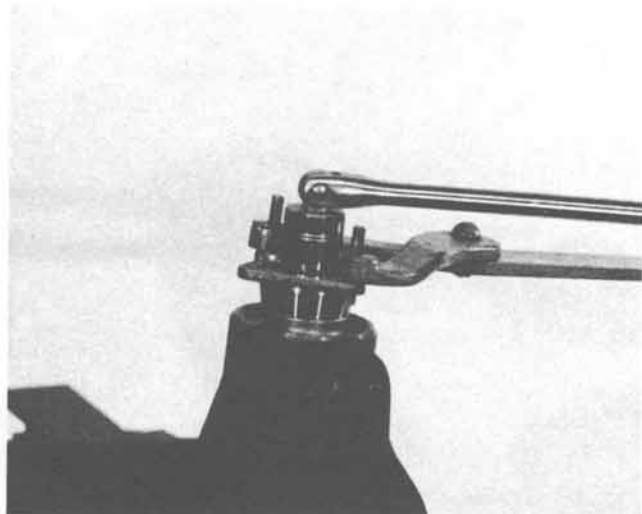

Figure 13

5329-13

Hold the companion flange with a tool similar to the one shown and remove the pinion nut and washer.

Tool: C-3281 Holding Wrench

DIFFERENTIAL CARRIER DISASSEMBLY

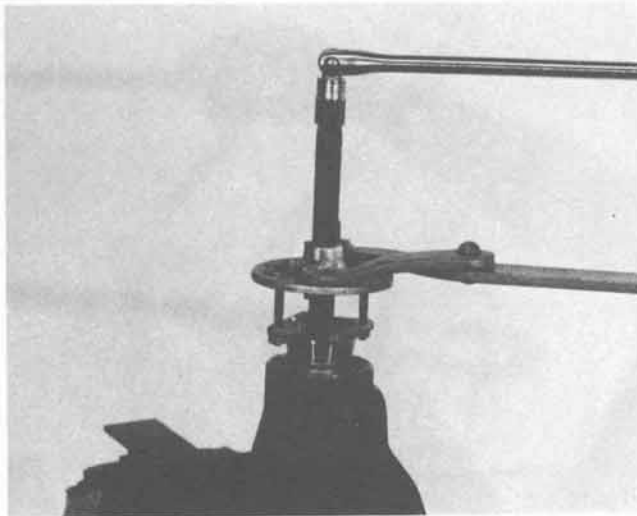

Figure 14

5329-14

Remove the companion flange with tools as shown. If the flange shows wear in the area of the seal contact, it should be replaced.

Tools: C-452 Companion Flange Remover
C-3281 Holding Wrench



Figure 15

5329-15

Remove the pinion by tapping with a rawhide or heavy-duty plastic hammer. Catch the pinion with your hand to prevent it from falling and being damaged.

NOTE

On the spline end of the pinion, there are bearing preload shims. These shims may stick to the outer bearing and then fall to the floor. Be sure to collect all these shims and keep them together since they will be used later in assembly. If shims are mutilated, replace with new ones. Shims are available in thicknesses of .003" (.08 mm), .005" (.13 mm), .010" (.25 mm), and .030" (.76 mm).

Remove the pinion oil seal. Discard the seal and replace with a new seal at the time of assembly. Remove the outer pinion bearing cone and outer pinion oil slinger.



Figure 16

5329-16

Remove the inner pinion bearing cup with tools as shown. Caution: Do not nick carrier bore.

Tools: D-148 Remover
C-4171 Handle

NOTE

THERE ARE TWO SEPARATE METHODS FOR CONTROLLING PINION POSITION.

Method A uses pinion position shims located between the inner bearing cup and carrier bore. If the shims are bent or nicked, they should be replaced at time of assembly. Measure each shim individually and wire the shim stack together. If the stack has to be replaced, replace it with the same thickness.

Method B is explained after Figure 18.

DIFFERENTIAL CARRIER DISASSEMBLY

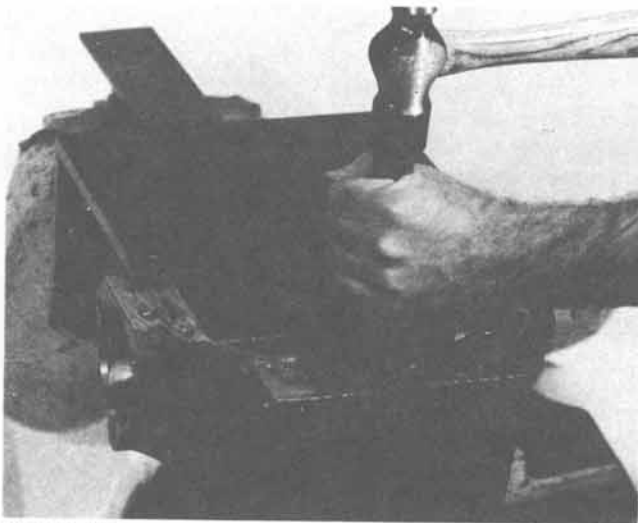

Figure 17

5329-17

Turn the nose of the carrier down. Remove the outer pinion bearing cup as shown. Caution: Do not nick the carrier bore.

Tools: D-147 Remover
D-4171 Handle
C-4291 Extension

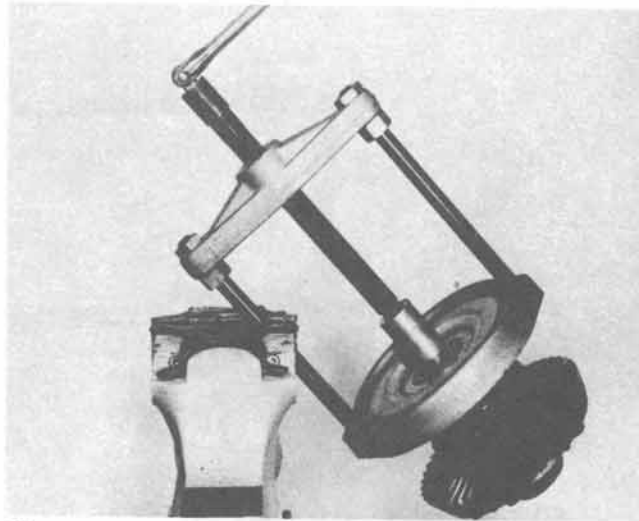

Figure 19

5329-19

Remove the differential bearings with a puller as shown. Wire the shims, bearing cup and bearing cone together, and identify from which side they were removed (ring gear side or opposite side). If the shims are mutilated, replace with new ones at time of assembly. Shims are available in thicknesses of .003" (.08 mm), .005" (.13 mm), .010" (.25 mm), and .030" (.76 mm). Reposition the case in the puller and remove the other bearing cone as described above.

Tools: DD-914-P Press
DD-914-9 Adapter Ring
C-293-18 Adapter Set
C-293-3 Adapter Plug

If the original shim stack or equivalent replacement for each side is available, the shim stack may be used as a starting point to assemble the differential case. Assemble the shim stack and new bearings on the same side which they were taken from, and install the differential case into the carrier as described later in the manual. Follow the procedures of measuring and adjusting backlash.

If the original shim stacks are lost or cannot be accurately determined, it is recommended that the shim stacks be found by using the procedures described in this manual.

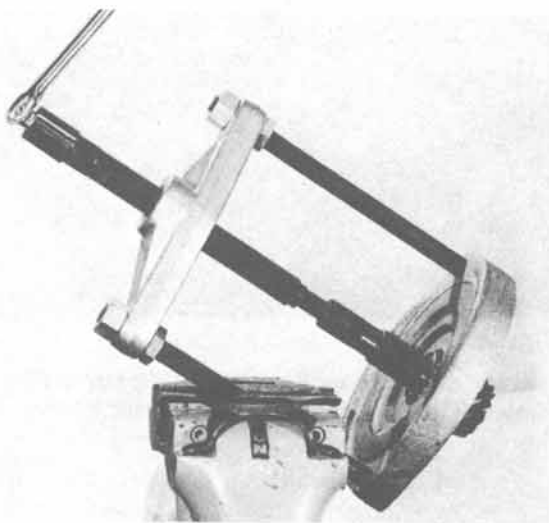

Figure 18

5329-18

Remove the inner pinion bearing cone with tools as shown.

Tools: DD-914-P Press
DD-914-9 Adapter Ring
C-293-39 Adapter Set

NOTE

Method B uses a selected thickness pinion position shim located between the inner pinion bearing cone and the pinion gear. If the shim is bent or nicked, it should be replaced at time of assembly with a new one.

NOTE

It is recommended that whenever bearings are removed, they be replaced with new ones, regardless of mileage.

DISSASSEMBLY AND ASSEMBLY OF STANDARD DIFFERENTIAL

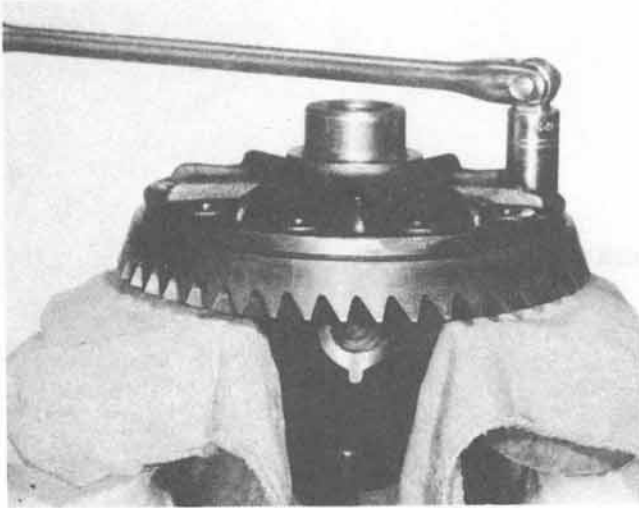

Figure 20

5329-20

Place a few shop towels over the vise to prevent the ring gear teeth from being nicked. Place the differential case in the vise as shown. Remove the ring gear screws.



Figure 22

5329-22

Position the differential case in a vise and drive out the lock pin which secures the pinion mate shaft to the case. Use a small drift as shown.

NOTE

It is recommended that whenever the ring gear screws are removed, they be replaced with new ones, regardless of mileage.



Figure 21

5329-21

Tap the ring gear with a rawhide or heavy duty plastic hammer to free it from the case. Remove the case and ring gear from the vise.

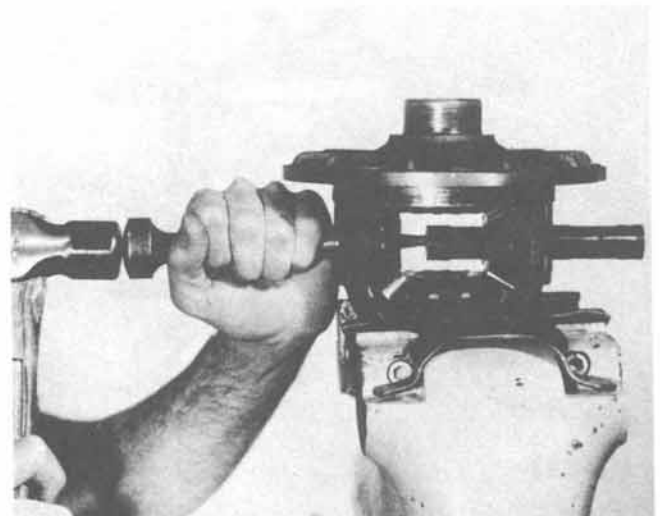

Figure 23

5329-23

Remove the pinion mate shaft with a drift as shown.

DISASSEMBLY AND ASSEMBLY OF STANDARD DIFFERENTIAL

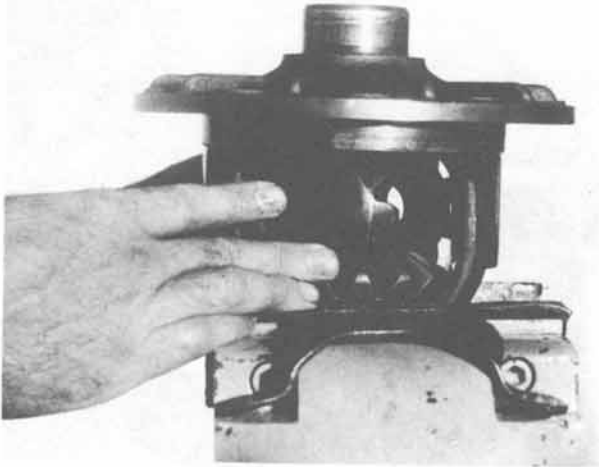

Figure 24

5329-24

Rotate the pinion mate gears and side gears until the pinion mates turn to the windows of the case. Remove the pinion mate gears and spherical washers. Lift the side gears and thrust washers out of the case. Inspect all the parts, including the machined surfaces of the case. If excessive wear is visible on all the parts, it is suggested that the complete differential assembly be replaced. If any one of the gears need to be replaced, then both gears are to be replaced as a set.



Figure 26

5329-26

Assemble the pinion mate shaft. Make sure the lock pin hole in the shaft lines exactly with the lock pin hole in the case.

Assemble the lock pin. Peen some metal of the case over the pin to lock it in place.

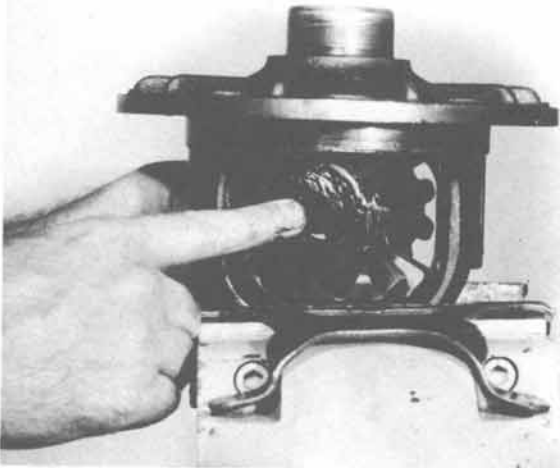

Figure 25

5329-25

Place the differential case in a vise. Apply a good quality grease to the new side gear thrust washers and to the hub and thrust face of the new side gears, and assemble into the case. Lubricate the new pinion mate gears and spherical washers. Hold the side gears in place with one hand, and assemble the pinion mate gears and spherical washers with the other hand. Rotate the side gears and pinion mate gears until the holes of the washers and pinion mate gears line up exactly with the holes in the case.

NOTE

Limited slip differentials for this particular application (Model 44-ICJ) are serviced as complete assemblies only. Follow the differential installation procedures described in this manual if a new differential is required.

REASSEMBLY

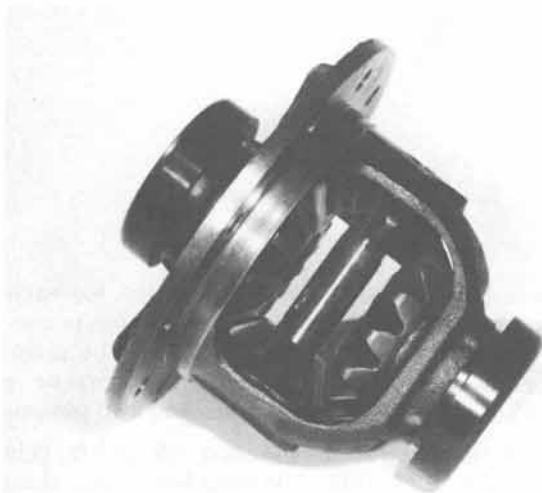

Figure 27

5329-27

Install the master differential bearings onto the case. Remove all nicks, burrs, dirt, etc., from the hubs to allow the master bearings to rotate freely.

Tool: D-345 Master Bearings

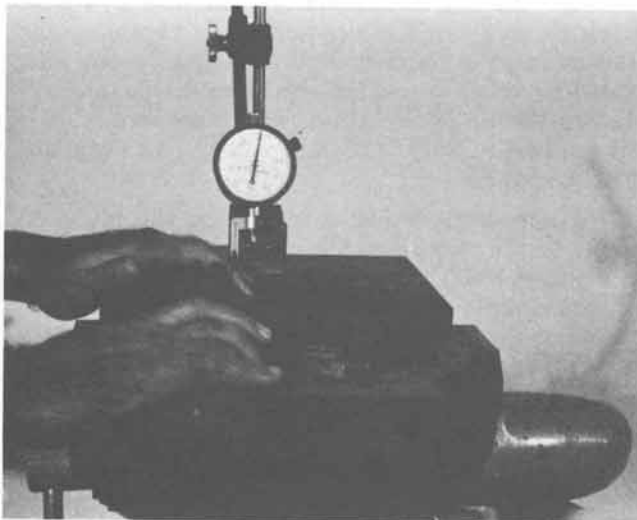

Figure 28

5329-28

Assemble the differential case into the carrier (less pinion). Mount a dial indicator with a magnetic base to the supporting fixture and indicate on the flange face as shown. Locate the tip of the indicator on the machined surface of the flange face. Force the differential assembly as far as possible in the direction towards the indicator. With force still applied, set indicator at zero (0).

Tool: D-128 Indicator

NOTE
If an indicator other than D-128 is used, it should be capable of a minimum of .200" (5.08 mm) travel.

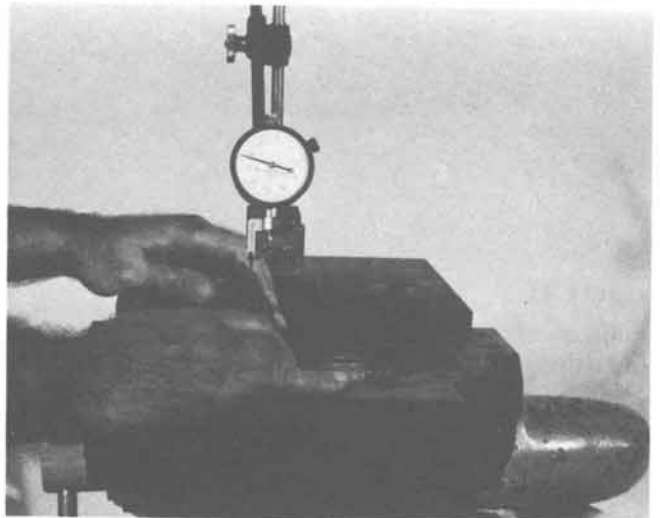

Figure 29

5329-29

Force the differential assembly as far as it will go in the opposite direction. Repeat these steps until the same reading is obtained.

Record the reading of the indicator. This amount, in shims, will be included in the final assembly shim stack to establish differential bearing preload and ring gear and pinion backlash.

After making sure the readings are correct, remove the indicator and differential assembly from the carrier.

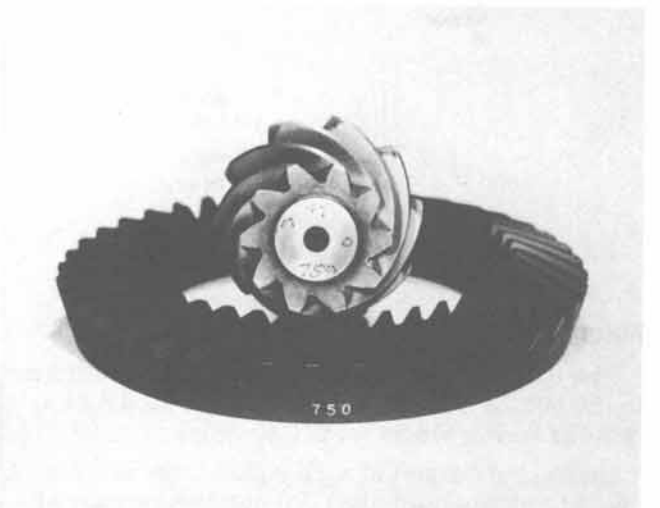

Figure 30

5329-30

View of ring and pinion etched with inch identification.

REASSEMBLY

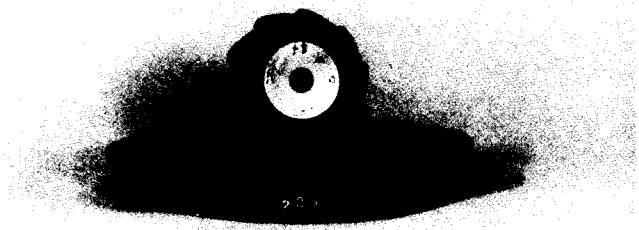

Figure 31

5329-31

View of ring and pinion etched with metric identification.

Ring gear and pinions are supplied in matched sets only. Matching numbers on both pinion and ring gear are etched for verification. If a new gear set is being used, verify the numbers on each pinion and ring gear before proceeding with the assembly.

which indicates the best running position for each particular gear set. The position of the pinion is controlled by the amount of shims between the inner pinion bearing cup and carrier bearing bore or a selected shim between the inner bearing and pinion.

For example, if a pinion is etched +3 (m+8), this pinion would require .003" (.08 mm) less shims than a pinion etched "0". This means that by removing .003" (.08 mm) of shims, the mounting distance of the pinion is increased to 2.628" (66.75 mm), which is just what a +3 (m+8) indicates. Or if a pinion is etched -3 (m-8), we would want to add .003" (.08 mm) more shims than would be required by a pinion that is etched "0". By adding .003" (.08 mm) shims, the mounting distance of the pinion was decreased to 2.622" (66.60 mm) which is just what a -3 (m-8) etching indicates.

If the old ring and pinion set is to be reused, measure the old shim stack and build a new shim stack to this same dimension. It is recommended that each shim be measured individually and then added together to obtain the shim stack total. To change the pinion position, shims are available in thicknesses of .003" (.08 mm), .005" (.13 mm), and .010" (.25 mm).

If a new gear set is used, notice the plus (+), minus (-), or zero (0) etching on both the old and new pinion and adjust the thickness of the new shim pack to compensate for the difference between these two pinion etchings. The chart in Figure 33 or 34 is helpful for determining this change.

For example: If the old pinion is etched +2 (m+5) and is at proper pinion position and the new pinion is etched -2 (m-5), then add .004" (.10 mm) to the original shim stack thickness in order to install the new pinion at proper position.

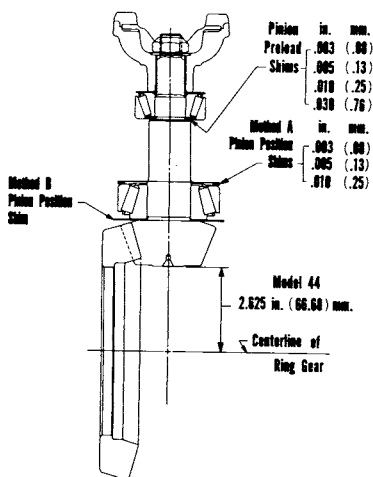

Figure 32

5329-32

The distance from the centerline of the ring gear to the button end of the pinion for the Model 44 axle is 2.625 inches (66.68 mm).

On the button end of each pinion there is etched a plus (+) number, a minus (-) number, or a zero (0),

REASSEMBLY

Old Pinion Marking	New Pinion Marking								
	-4	-3	-2	-1	0	+1	+2	+3	+4
+4	+0.008	+0.007	+0.006	+0.005	+0.004	+0.003	+0.002	+0.001	0
+3	+0.007	+0.006	+0.005	+0.004	+0.003	+0.002	+0.001	0	-0.001
+2	+0.006	+0.005	+0.004	+0.003	+0.002	+0.001	0	-0.001	-0.002
+1	+0.005	+0.004	+0.003	+0.002	+0.001	0	-0.001	-0.002	-0.003
0	+0.004	+0.003	+0.002	+0.001	0	-0.001	-0.002	-0.003	-0.004
-1	+0.003	+0.002	+0.001	0	-0.001	-0.002	-0.003	-0.004	-0.005
-2	+0.002	+0.001	0	-0.001	-0.002	-0.003	-0.004	-0.005	-0.006
-3	+0.001	0	-0.001	-0.002	-0.003	-0.004	-0.005	-0.006	-0.007
-4	0	-0.001	-0.002	-0.003	-0.004	-0.005	-0.006	-0.007	-0.008

Figure 33

5329-33

Pinion setting chart (inch).

Old Pinion Marking	New Pinion Marking								
	-10	-8	-5	-3	0	+3	+5	+8	+10
+10	+0.20	+0.18	+0.15	+0.13	+0.10	+0.08	+0.05	+0.03	0
+8	+0.18	+0.15	+0.13	+0.10	+0.08	+0.05	+0.03	0	-0.03
+5	+0.15	+0.13	+0.10	+0.08	+0.05	+0.03	0	-0.03	-0.05
+3	+0.13	+0.10	+0.08	+0.05	+0.03	0	-0.03	-0.05	-0.08
0	+0.10	+0.08	+0.05	+0.03	0	-0.03	-0.05	-0.08	-0.10
-3	+0.08	+0.05	+0.03	0	-0.03	-0.05	-0.08	-0.10	-0.13
-5	+0.05	+0.03	0	-0.03	-0.05	-0.08	-0.10	-0.13	-0.15
-8	+0.03	0	-0.03	-0.05	-0.08	-0.10	-0.13	-0.15	-0.18
-10	0	-0.03	-0.05	-0.08	-0.10	-0.13	-0.15	-0.18	-0.20

Figure 34

5329-34

Pinion setting chart (metric).

Use these charts as a guideline to set pinion position.

REASSEMBLY



Figure 35

5329-35

View of master pinion block, pinion height block, scooter gage, cross arbor and arbor discs.

NOTE

Be sure that all carrier bores are free from all nicks, dirt or any other contamination.

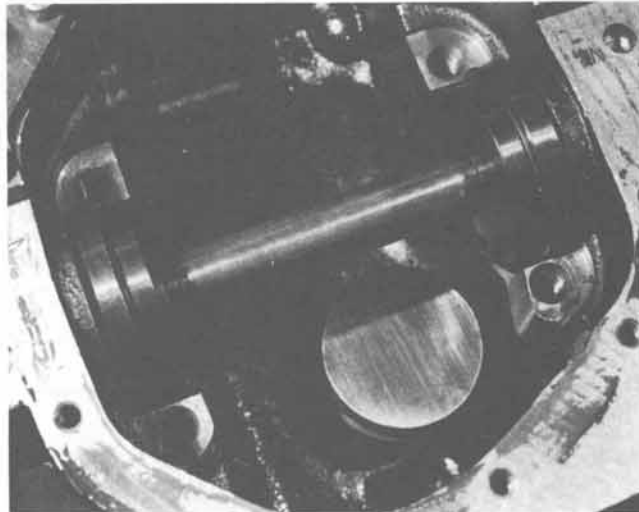

Figure 37

5329-37

Place the arbor discs and arbor into the cross bores of the carrier as shown.

Tools: D-115-3 Arbor
D-115-4-44 Arbor Discs

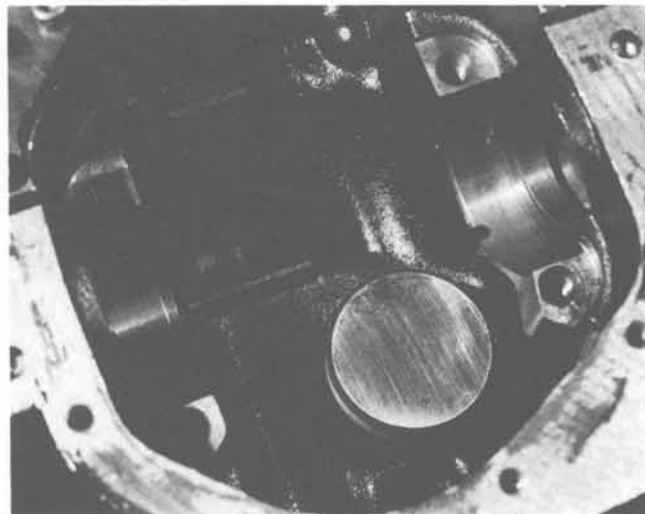

Figure 36

5329-36

Place the master pinion block into the inner pinion bearing bore of the carrier as shown.

Tool: D-139 Master Pinion Block

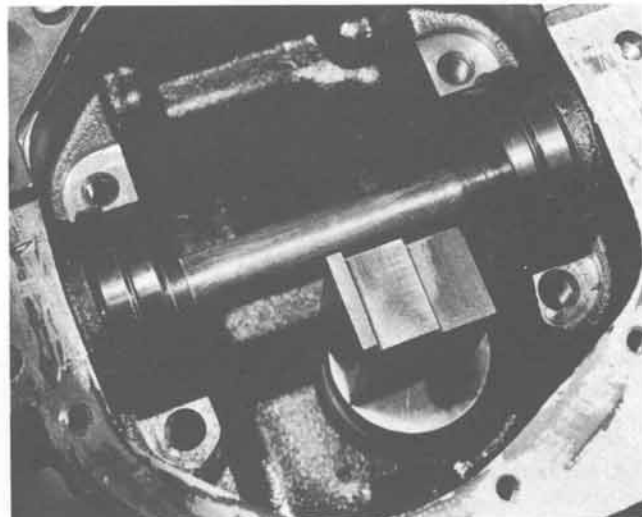

Figure 38

5329-38

Place the pinion height block on top of the master pinion block and against the arbor as shown.

Tool: D-115-1 Pinion Height Block

REASSEMBLY

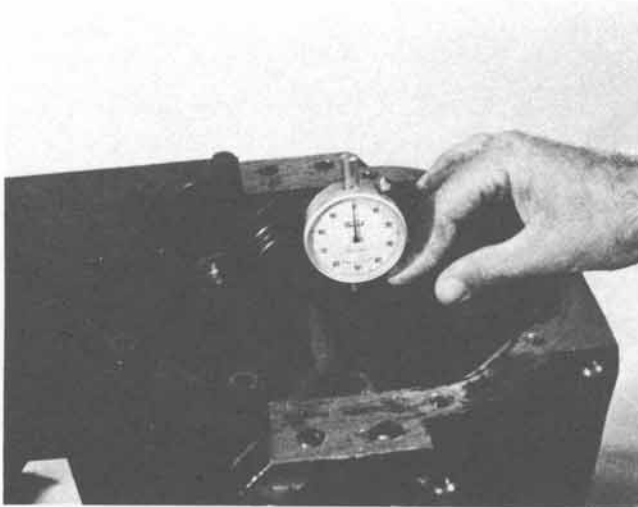

Figure 39

5329-39

Place the scooter gage on the pinion height block. Apply light pressure with fingers at the back side of the scooter gage. Make sure the scooter gage is flat on the pinion height block, then set the indicator at zero (0).

Tool: D-115 Scooter Gage

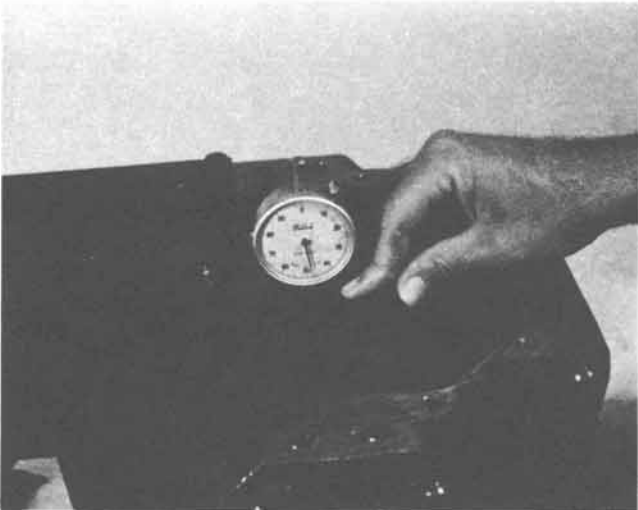

Figure 40

5329-40

Slide the scooter gage towards the arbor. As the indicator moves over the top of the arbor, the dial will move in a clockwise direction across the face of the indicator. When the indicator is at the top center of the arbor, the dial will stop traveling in a clockwise direction. If the dial starts to move in a counter-clockwise direction, this means that you have passed the top center position on the arbor. Record only the reading when the indicator is at top center on the arbor and the dial has stopped moving clockwise on the indicator face. This reading indicates the thickness of the shim stack that is required to install a pinion that is etched with a zero (0) at a zero (0) position. If the pinion being installed

has a plus (+) or minus (-) etching, then an adjustment of this shim stack is required.

For example: If a pinion is etched +3 (m+8), then this pinion would require .003" (.08 mm) less shims than a pinion etched zero (0). If a pinion is etched -3 (m-8), we would want to add .003" (.08 mm) more shims to the shim stack than would be required if the pinion were etched zero (0).

Remove the special tools.

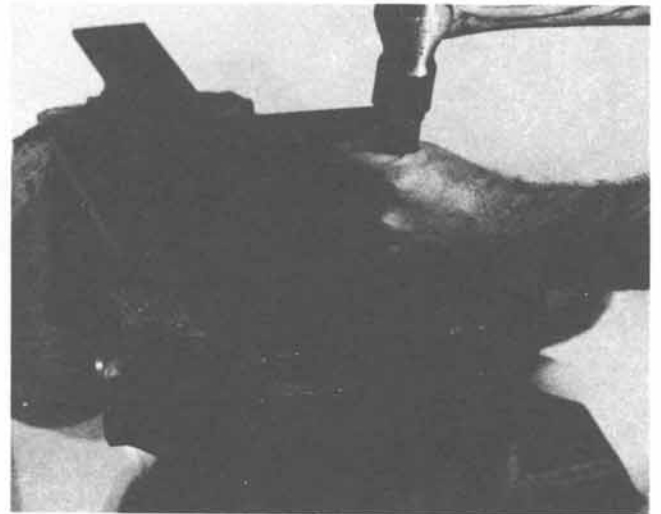

Figure 41

5329-41

Measure each shim separately for Method A with a micrometer and add together to get the total shim stack thickness. Place the required amount of shims in the inner pinion bearing bore. Drive the inner pinion bearing cup into the carrier with tools as shown.

Tools: D-145 Installer
C-4171 Handle



Figure 42

5329-42

Assemble the outer pinion bearing cup into carrier as shown.

Tools: D-144 Installer
C-4171 Handle

REASSEMBLY



Figure 43

5329-43

Measure the selected shim for Method B as determined in Figure 40 and install it on the pinion. Assemble the inner pinion bearing cone on the pinion. Place the bearing installer over pinion shaft as shown. Drive the bearing on the shaft until it is completely seated.

Tool: W-262 Installer



Figure 45

5329-45

Assemble the washer and pinion nut. Torque the nut until it requires 10 lbs. in. (1.13 N•m) to rotate the pinion. Rotate the pinion several revolutions before checking pinion position. This is done to seat the bearings and assure a more accurate reading.

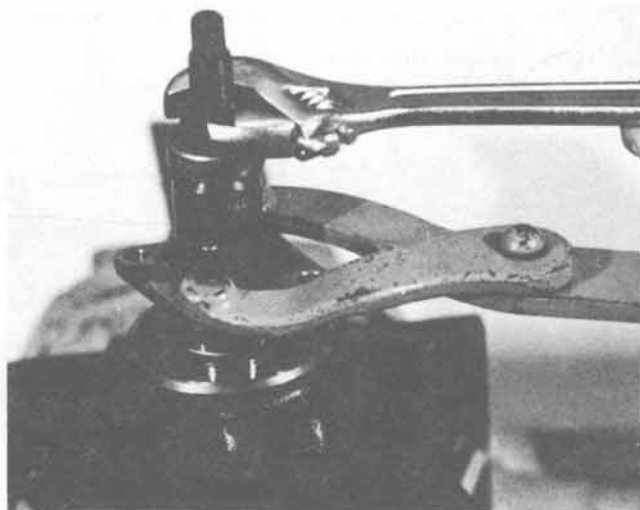

Figure 44

5329-44

Insert the pinion into the carrier.

Assemble the outer pinion bearing cone, slinger and companion flange onto pinion spline (do not assemble the oil seal and pinion bearing preload shims at this time).

Use the yoke installer (as shown) to draw the companion flange onto the pinion spline.

Tools: W-162 Installer
C-3281 Holder

NOTE

The reason for not assembling the pinion oil seal and preload shims at this time is due to the possibility of having to adjust pinion bearing preload or pinion position. It would be necessary to again remove the oil seal; and as mentioned, whenever seals are removed, they are to be replaced with new ones.

REASSEMBLY

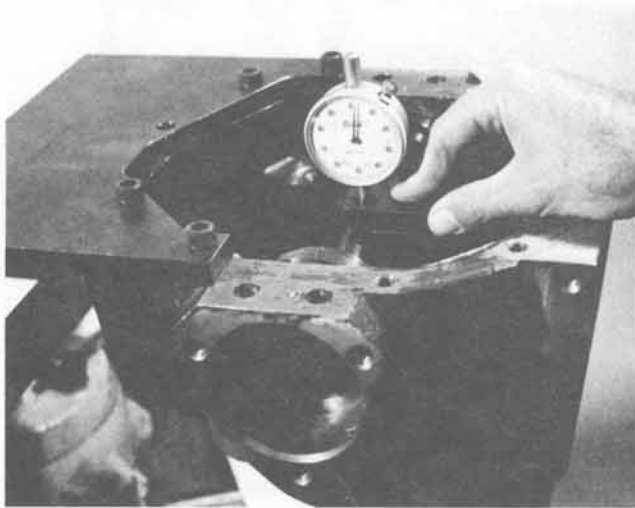

Figure 46

5329-46

Place the arbor discs and arbor into the cross bore of the carrier. Place the pinion height block on the button end of the pinion. Set dial indicator of scooter gage at zero (0). Slide the scooter gage towards the arbor. As discussed in Figure 40, the indicator will show the greatest clockwise reading when it is at the top center of arbor. This reading indicates the position of the pinion.

An indicator reading within .002" (.05 mm) of the etching on the pinion is considered acceptable. If pinion position is not within plus or minus (\pm) .002" (.5 mm) of the etching on the button of the pinion, refer to the pinion setting charts in Figures 33 or 34 as a guide to how much change in the shim stack is needed to position the pinion properly.

For example: If the etch on the bottom of the pinion is +2 (m+5) and the indicator reading is $-.003$ " ($-.08$ mm), the pinion is installed too close to the centerline of the differential crossbore. It is not within the acceptable tolerance of $\pm .002$ " ($\pm .05$ mm) of the pinion etch. Referring to the charts in Figures 33 or 34, in order to move from a position of -3 (-8) to the correct position of +2 (+5), we need to remove .005" (.13 mm) of shims from the shim stack or use a .005" (.13 mm) smaller selected shim.

Follow the recommended procedures for removing the shim stack or selected shim and make the change. Reinstall the pinion according to Figure 44 to 45.

Tools: D-115-3 Arbor
D-115-4-44 Arbor Discs
D-115-1 Pinion Height Block
D-115 Scooter Gage

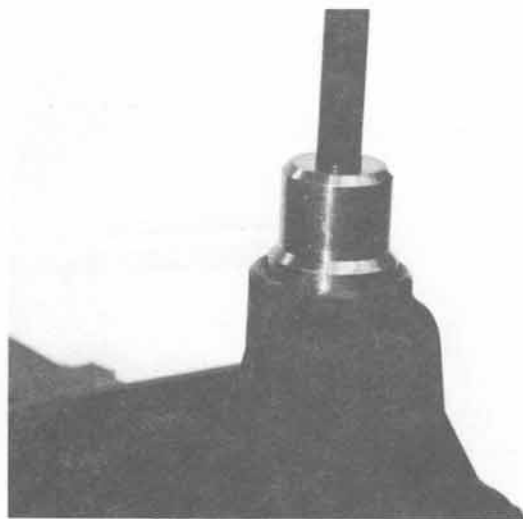

Figure 47

5329-47

When the pinion position is within the acceptable tolerance of $\pm .002$ " (.05 mm) of the pinion etch, remove the pinion nut, washer, companion flange, slinger, outer pinion bearing cone and the pinion. Lubricate the inner and outer bearings by applying a small amount of the specified lube on the rollers of the bearing cone. Install the outer bearing cone and oil slinger into the carrier. Apply a light coat of oil to the lip of a new pinion oil seal, and assemble the seal into the carrier as shown.

Tools: W-147-E Seal Installer
C-4171 Handle

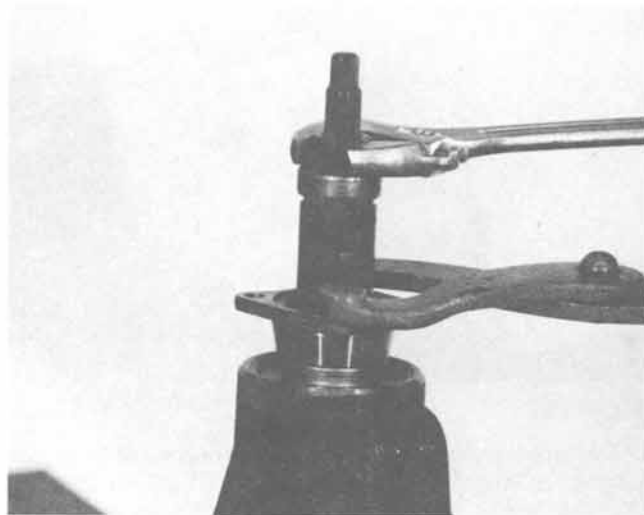

Figure 48

5329-48

Assemble the preload shims, which are equal in thickness to the original shim stack, onto the pinion. Insert the pinion into the carrier. Assemble the companion flange onto the spline of the pinion.

Tools: W-162 Installer
C-3281 Holder

REASSEMBLY

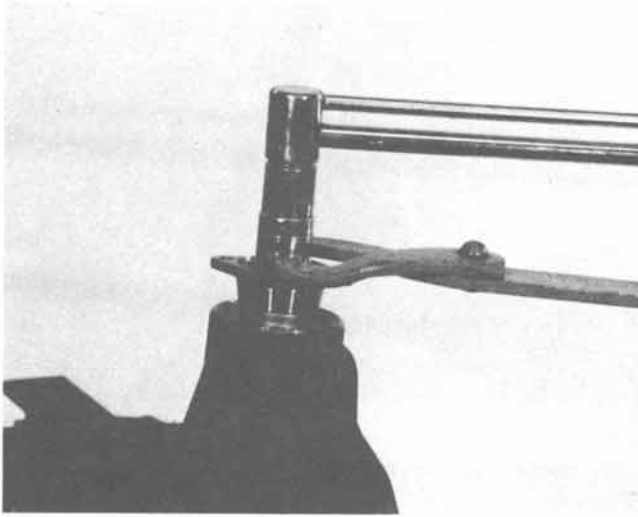

Figure 49

5329-49

Assemble the pinion washer and the new pinion nut. Torque the pinion nut to 200-220 lbs. ft. (271-298 N•m).

Tools: C-3281 Holder
C-4053 Torque Wrench

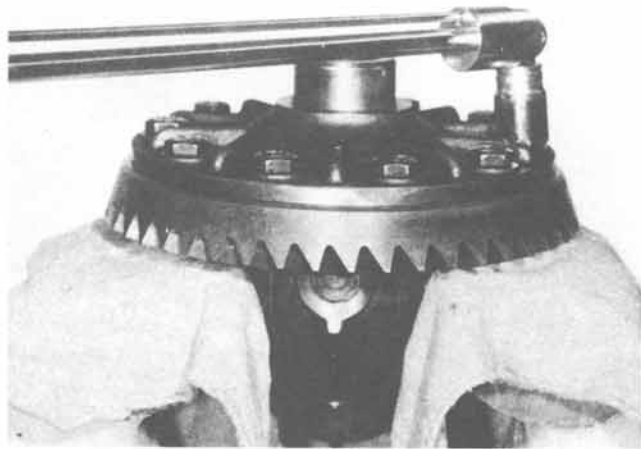

Figure 51

5329-51

Be sure the flange face of the differential case is free of nicks or burrs. Assemble the ring gear to the differential case using new ring gear screws. Draw the screws up alternately and evenly. Torque the screws to 45-60 lbs. ft. (68-81 N•m).

Tool: C-3952-A Torque Wrench

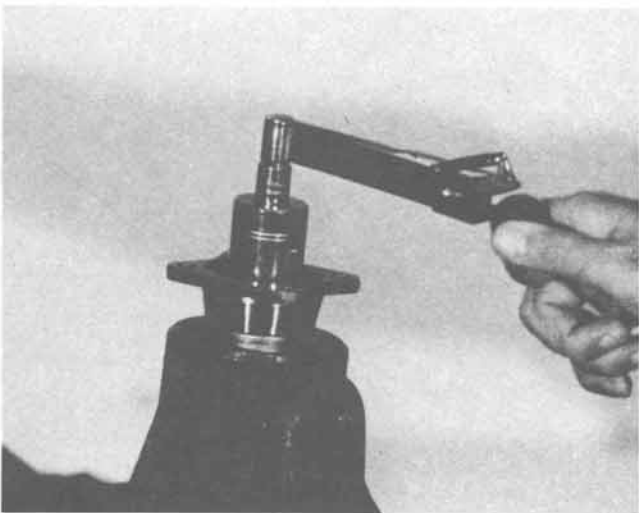

Figure 50

5329-50

Using an inch-pound torque wrench as shown, the pinion rotating torque should read 20-40 lbs. in. (2.3-4.5 N•m) with new bearings. To increase the preload, remove shims; to decrease the preload, add shims.

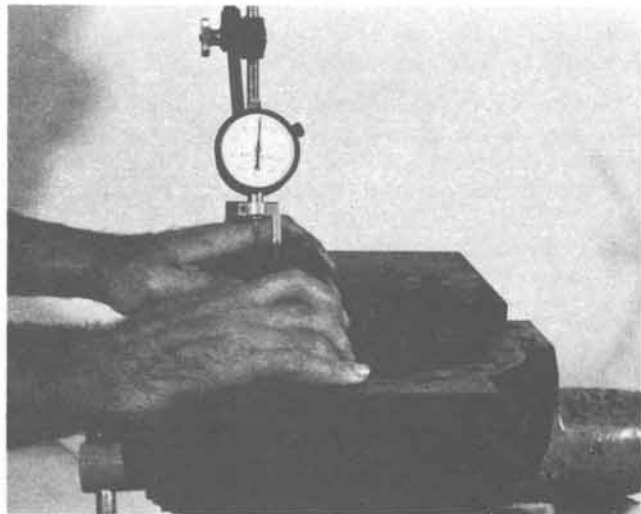

Figure 52

5329-52

Install the master differential bearings onto the case. Remove all nicks, burrs, dirt, etc., from the hubs to allow the master bearings to rotate freely.

Place the differential assembly into the carrier. Set up the dial indicator as shown. Force the differential assembly away from the pinion gear until it is completely seated against the cross bore face of the carrier. With force still applied to the differential case, place the tip of dial indicator on a flat machined surface of the differential case, if available, or on the head of a ring gear screw, and set the indicator at zero (0).

Tools: D-128 Dial Indicator
D-345 Master Bearings

REASSEMBLY

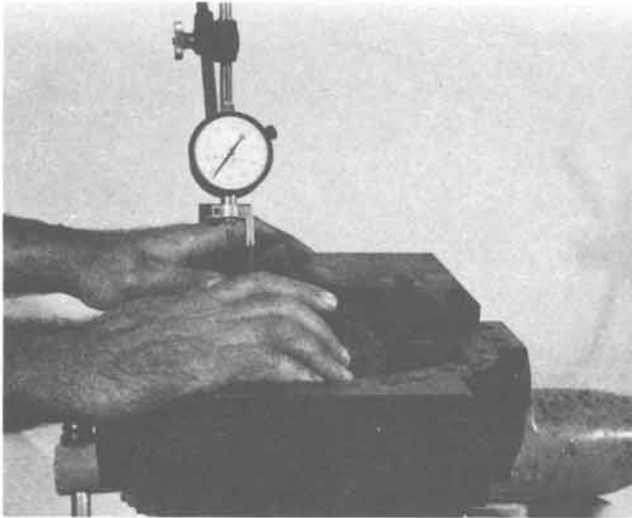

Figure 53

5329-53

Force the ring gear to mesh with the pinion gear. Rock the ring gear slightly to make sure the gear teeth are meshed. Repeat this procedure several times until the same reading is obtained each time. Be sure the indicator reads zero (0) each time the ring gear is forced back into contact with the cross bore face. This reading will be the necessary amount of shims between the differential case and differential bearing on the ring gear side. Remove the dial indicator and the differential case from carrier. Remove the master bearings from the differential case.



Figure 54

5329-54

Place the differential case onto the adapter as shown.

Assemble the required amount of shims to the ring gear side hub as determined in Figure 53. Place the bearing cone on the hub of the differential case. Use the bearing installer to seat the bearing cone as shown.

The adapter is used to prevent possible damage to

hubs while assembling bearing cones.

Tools: C-4487-1 Adapter
D-156 Installer
C-4171 Handle

Assemble the remaining shims of the total shim pack. Add an additional .010" (.25 mm) to the remaining shims. Assemble the opposite side differential bearing cone as shown.

EXAMPLE: In Figure 29 a total of .077" (1.96 mm) was recorded. In Figure 53 a total of .059" (1.50 mm) was recorded.

This leaves a balance of .018" (.46 mm) for opposite side ring gear, and adds up to .077" (1.96 mm) which was obtained at the start.

To compensate for preload and backlash, add .010" (.25 mm) to the opposite side. The shim pack totals for this example are as follows:

Ring gear side: (.059" (1.50 mm))

Opposite side: Original Balance of .018" (.46 mm) plus .010" (.25 mm) gives .028" (.71 mm).

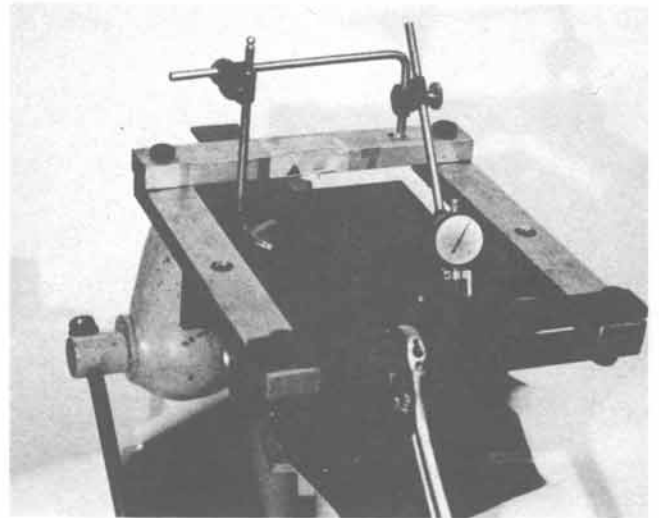

Figure 55

5329-55

Install the spreader and indicator to the carrier as shown. Spread the carrier .010" (.25 mm) for differential installation.

DO NOT SPREAD THE CARRIER OVER .010" (.25 mm).

Tools: D-113 Spreader
D-227-1 Spreader Adapters
D-128 Dial Indicator Set

Remove the indicator.

REASSEMBLY

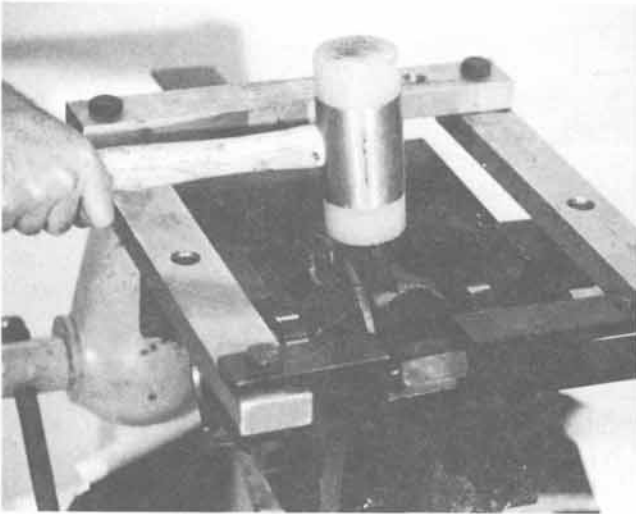

Figure 56

5329-56

Assemble the differential bearing cups to the differential bearing cones.

Install the differential assembly into the carrier.

Use a rawhide or heavy-duty plastic hammer to seat the differential assembly into the cross bore of the carrier. Care should be taken to avoid nicking the teeth of the ring gear or pinion during assembly.

Remove the spreader.

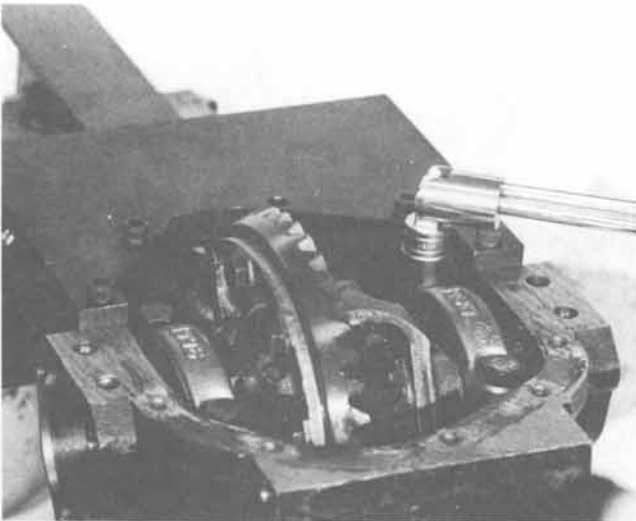

Figure 57

5329-57

Install the bearing caps and screws. Make sure the letters stamped on the caps correspond in both position and direction with the letters stamped into the carrier as noted in Figure 10.

Torque the bearing cap screws to 80-90 lbs. ft. (108-122 N•m).

Tool: C-3952-A Torque Wrench

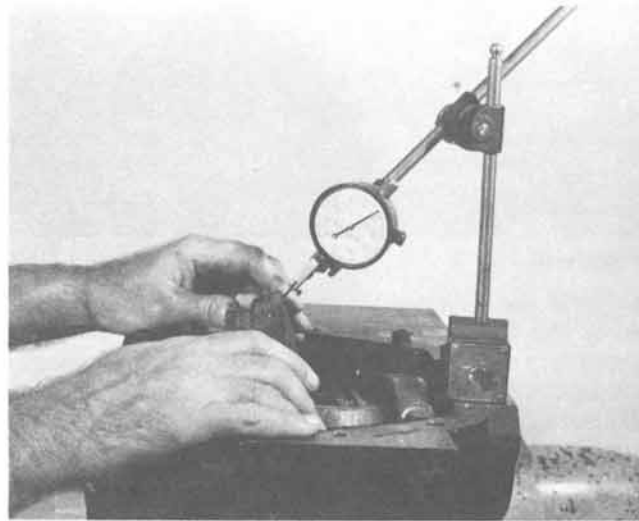

Figure 58

5329-58

Check the ring gear and pinion backlash in three equally spaced points with a dial indicator as shown. Backlash tolerance is .005" (.13 mm) to .008" (.20 mm) and cannot vary more than .003" (.08 mm) between points checked.

High backlash is corrected by moving some shims from the opposite side of the differential case to the ring gear side; thus moving the ring gear closer to the pinion.

Low backlash is corrected by moving some shims from the ring gear side of the differential case to the opposite side; thus moving the ring gear away from the pinion.

Tool: D-128 Dial Indicator

REASSEMBLY

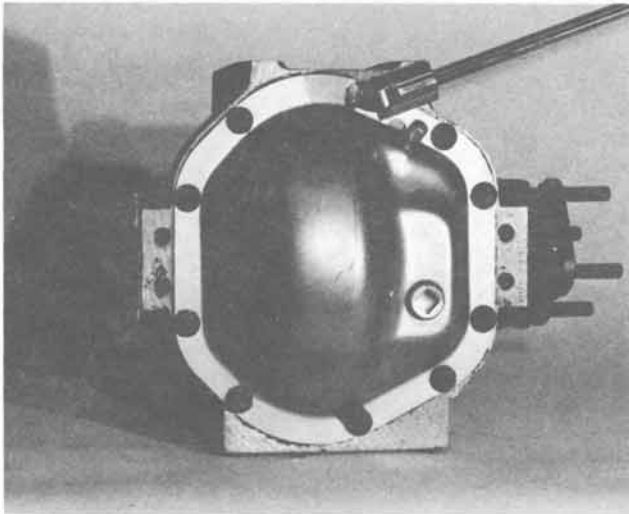

Figure 59

5329-59

The mating surfaces of the carrier cover and the carrier should be free of dirt, oil, etc. Apply the sealer to the carrier face as shown. The sealer bead is to be 1/8" (3.18 mm) to 1/4" (6.35 mm) wide and should be continuous, and should not pass through or outside of the holes.

Sealant material must meet specification of ASTM 1, GE 503, Z1, Z2 and Z3 sealant.

Cover and carrier assembly must be assembled together within five minutes of gasket sealant application. Torque the cover screws 30-40 lbs. ft. (27-54 N•m).

NOTE

Use of cleaning solvent may prevent the silicone rubber sealant from adhering to the carrier face and cover, resulting in leaks of axle lubricant.

Assemble the axle shaft assemblies as outlined in this manual. Fill the carrier assembly with the specified type and amount of hypoid lubricant.

When the carrier assembly is rebuilt to proper specifications, refer to the vehicle manufacturer's recommendations for the proper installation procedures into the vehicle.

**WE SUPPORT
VOLUNTARY MECHANIC
CERTIFICATION
THROUGH**



Dana Corporation, Spicer Axle Division, reserves the right to make changes from time to time, without notice or obligation, in specifications, descriptions, and illustrations, and to discontinue models or revise designs.

Questions regarding this manual should be directed to:

Spicer Axle Division
Dana Corporation
P.O. Box 1209
Fort Wayne, Indiana 46801
Attention: Engineering Technical Service Dept.